



# Product Specifications

## VC-6000 Monitoring System

### Monitoring Module – SM-610-160

2x Vibration (2x User-defined Bandwidth, 4x Tracking Filter), 2x Speed Channels, 6x DC Outputs, 8x Relays

*The VC-6000 Monitoring System hardware is used for both stand-alone safety monitoring and condition monitoring using the Compass 6000 monitoring software modules and database. The VC-6000 offers various standard monitoring modules, power supply modules and communication modules. These Product Specifications describe the SM-610-160.*

#### Applications

The SM-610 series of VC-6000 Monitoring Modules are designed to provide protective monitoring of various types of industrial machines. The SM-610-160 is specifically designed for vibration monitoring of a 2-spool gas turbine (such as the LM2500) for compressor or power generation applications.

#### General Description

The features and functions common to all SM-610 Monitoring Modules are briefly listed below. Please refer to the VC-6000 Product Specifications (BPS 0044) for more information.

- Interfacing with the CI-6xx Communication Modules
- High speed digital signal processor
- Relay outputs (logic controlled)
- OK-relay status indication
- Extensive local LED indication
- Flash memory for storing settings and local logbook
- High speed reaction time - 10ms
- Alarm limits with programmable hysteresis and response delay time
- Global trip multiply and override
- Extensive self-monitoring functions
- System bus interface to other modules
- Buffered vibration outputs



#### Inputs

- 2x vibration signals – single-point measurements
- 2x speed/phase reference signals
- 3x binary input signals

#### Outputs

- 6x analogue DC outputs
- 8x relays (4x Danger, 4x alert):
  - 4x speed
  - 2x static bandpass – 1-out-of-4 voting logic
  - 2x tracking narrowband – 1-out-of-2 voting logic

Product Specifications - VC-6000 Monitoring Module – SM-610-160

Measurements

- 2x bandpass (user-defined filter)
- 4x tracking filter bandpass
- 2x RPM

Input Channel Configuration Combinations

<b>Monitoring Module – SM-610-160</b> 2x Vibration (2x User-defined Bandwidth, 4x Tracking Filter), 2x Speed Channels, 6x DC Outputs, 8x Relays																					
No. of Inputs <sup>1</sup>	Channel Types																Additional Measurements		Relay's		
	Dual-point Vibr. <sup>2</sup> (ISO)	DC-out	Single-point Vibr (ISO)	DC-out	Axial Pos.	DC-out	Speed	DC-out	Rod Drop	DC-out	Rel. Exp.	DC-out	Eccentricity	DC-out	DC Input (Process, Absolute Exp)	DC-out	Bin. in	Vector <sup>3</sup>	BP	Tracking BP	
4	4	2	2	4 <sup>2</sup>			2	2											2	4	2x 1oo1 for each RPM 2x 1oo4 for each One-point (1A & 2A:1BP & X1MA @ RPM1) 2x 1oo2 for each One-point (1A & 2A: X1MA @ RPM2)
<sup>1</sup> The number of input signals is the sum total of the channels shown in yellow. <sup>2</sup> DC-out: 2x One-point X1MA @ RPM1 and 2x One-point 1 X1MA @ RPM2																					

<sup>1</sup> The number of input signals is the sum total of the channels shown in yellow.

Signal Flow Diagrams

The nomenclature used in the diagrams refer specifically to a gas turbine application, but the SM-610-160 can also be used in other applications.

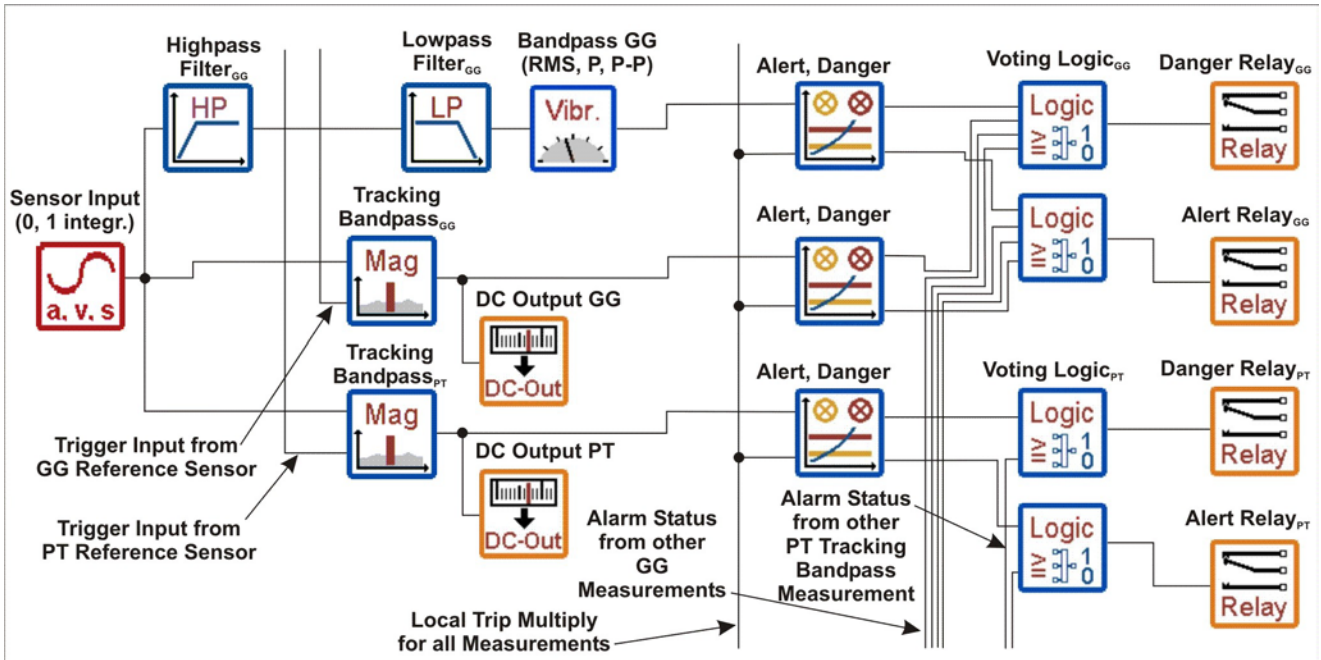

Figure 1. There are 2 identical AC/DC vibration inputs – One for forward position and one for aft position of the gas turbine. 1-of-4 voting logic is used for Alert and Danger alarms for the gas generator (GG) measurements (2 relays for user-defined bandpass and tracking filter measurement from the forward and aft position inputs). 1-of-2 voting logic is used for Alert and Danger alarms for the power turbine (PT) measurements (2 relays for the tracking filter measurements from the forward and aft position inputs).

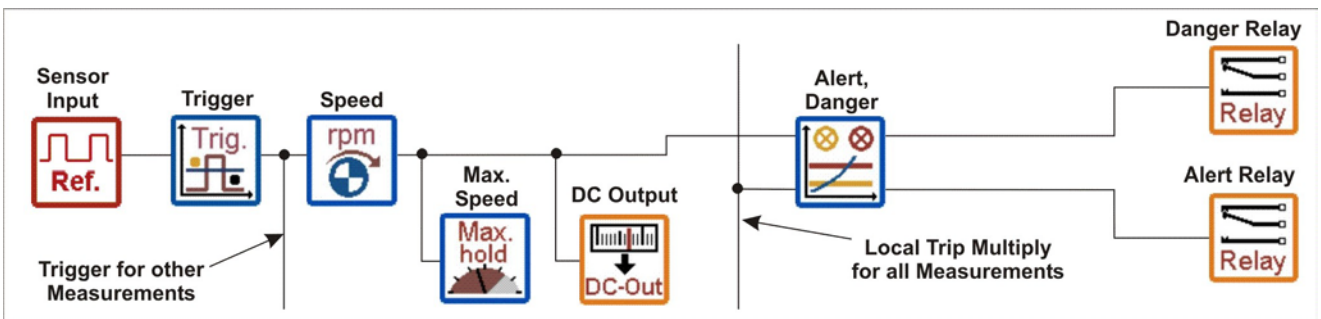

Figure 2. There are 2 speed/phase reference sensor inputs – One for the gas generator (GG) and one for the power turbine (PT).

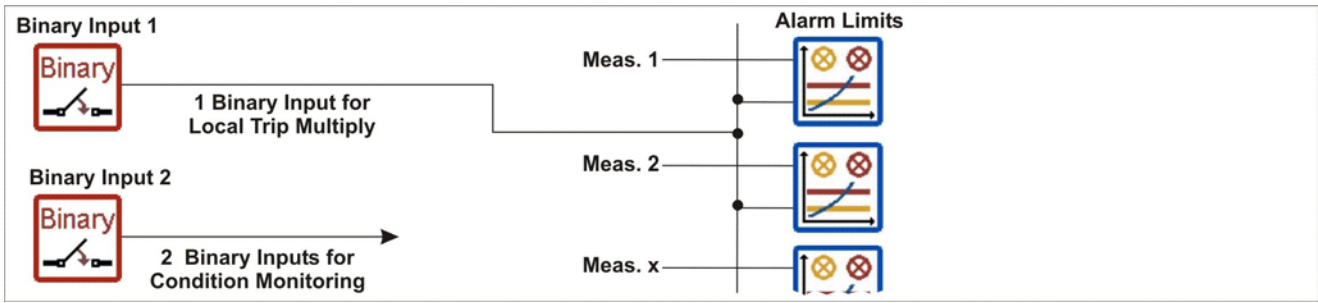

Figure 3. Binary input (3 channels – 1x for local trip multiply of all measurement alarm limits, 2x for condition monitoring purposes).

## Technical Specifications

The specifications given below are specific for the SM-610-160 Monitoring Module. See the VC-6000 Product Specifications for features and functions common to all SM-610 Monitoring modules.

### AC/DC Vibration Sensor Inputs

Input voltage range ..... -21.5 to -1V

#### Input frequency range:

Accelerometer/velocity sensor ..... 0.6Hz to 20kHz  
 Displacement sensor ..... DC to 20kHz

#### Input impedance:

Accelerometer ..... >800kΩ  
 Velocity sensor ..... 50kΩ  
 Displacement sensor ..... >800kΩ

#### Gain:

Accelerometer:  
 No integration ..... 1 to 80 (±0.75%)  
 Analogue integration ..... 1 to 80 (±2.75%)  
 Velocity sensor ..... 1 to 80 (±0.75%)  
 Displacement sensor ..... 1 (±0.75%)

#### Sensitivity:

Accelerometer ..... adjustable (typ. 100 or 10mV/g)  
 Velocity sensor . adjustable (typically 100mV/mm/s)  
 Displacement sensor ..... adjustable (typ. 8mV/μm)

#### Common mode rejection:

DC to 30kHz ..... typically 90dB  
 30kHz to 100kHz ..... typically 85dB

#### Maximum accelerometer input signal (100mV/g):

No integration ..... 1.25 to 80g peak  
 Analogue integration ..... 12.5 to 150mm/s peak

#### Sensor power:

Sensor supply ..... -24VDC ±2%  
 Maximum current ..... 30mA

### Speed/Phase Reference Sensor Inputs

Input voltage range ..... -21.5 to -1V  
 Input frequency range ..... DC to 20kHz  
 Input impedance ..... >800kΩ  
 Gain ..... 1 (±0.75%)

#### Common mode rejection:

DC to 10kHz ..... typically 90dB  
 10kHz to 100kHz ..... typically 85dB

#### Sensor power:

Sensor supply ..... -24VDC ±2%  
 Maximum current ..... 30mA

### Binary Inputs

Input impedance ..... 3.3kΩ  
 Response time ..... 5ms  
 Minimum current load ..... 5mA  
 Maximum contact voltage ..... ±50V

#### Signal status LOW:

Nominal input voltage ..... 0V  
 Input voltage range ..... -50 to 6.6V  
 Maximum input current ..... 2mA

#### Signal status HIGH:

Nominal input voltage ..... 24V  
 Input voltage range ..... 16.5 to 50V  
 Maximum input current ..... 5mA

**Buffered Outputs**

Minimum output load ..... 100kΩ  
 Output gain ..... 1 (±2%)  
 Cross-talk..... typically –90dB (up to 50kHz)  
 Inherent noise (1Hz to 50kHz)..... typically 10mV RMS  
 Output impedance ..... <100Ω  
 Frequency range..... DC to 50kHz (phase shift <5%)  
 Output offset ..... ≤ ±13mV

*Voltage output:*

Voltage range ..... 0 to 10V or 2 to 10V  
 Minimum output load ..... 1kΩ  
 Accuracy ..... <1.3% of measured value  
 Offset ..... <9.5mV

**Analogue DC Outputs**

*Current output:*

Current range..... 4 to 20mA or 0 to 20mA  
 Maximum output load ..... 500Ω  
 Accuracy ..... <2.4% of measured value  
 Offset ..... <20µA

**Relay Outputs**

Nominal working voltage..... 24V  
 Maximum current ..... 100mA

**Measurements**

Meas. Name	Frequency Range	Measuring Time	Detection	Alarm Limits	Measuring Range	Units <sup>1</sup>	Accuracy (25°C, 80Hz, 0-Peak)
Bandpass (User-defined filter)	HP: 1 to 10Hz (-1dB) LP: 1kHz (-1dB) 18dB/Octave (ISO 2954)	Adjustable 100ms to 100s in steps of 100ms	RMS, Peak, Peak-peak	1x Alert, 1x Danger	80g	g	±(0.08g + 0.75% of measured value)
					150mm/s (1 integration <sup>2</sup> )	mm/s	±(0.6mm/s + 2.75% of measured value)
					100mm/s	mm/s	±(0.1mm/s + 0.75% of measured value)
Tracking Bandpass	Centre freq.: 25 to 200Hz Bandwidth: 5Hz 36dB/Octave	1s	RMS, Peak, Peak-peak	1x Alert, 1x Danger	80g	g	±(0.08g + 0.75% of measured value)
					150mm/s (1 integration <sup>3</sup> )	mm/s	±(0.6mm/s + 2.75% of measured value)
					100mm/s	mm/s	±(0.1mm/s + 0.75% of measured value)
DC (radial)	-	Adjustable 10ms to 100s	-	2x Alert, 2x Danger	2mm	µm	±(2.0µm + 1.0% of measured value)
RPM (also Max. RPM)	Signal slope: +/- Trigger level <sup>4</sup> (manual or automatic): -21.5 to -1V; adjustable in steps of 0.1V Hysteresis: 0 to 25; adjustable in steps of 0.1	Adjustable 10ms to 100s	RPM	1x Alert, 1x Danger	0.06 to > 1200000 RPM RPM multiplier and divider adjustable from 1 to 99999	RPM	Speed >10000rpm: ±0.01% of measured value Speed 100 to 10000 rpm: ±1 rpm Speed < 100 rpm: ±0.1 rpm (one pulse per revolution)

<sup>1</sup> Metric and imperial units can be used; Metric units are shown only as an example.

<sup>2</sup> One analogue integration is possible. An additional digital integration can be done but this can result in less accuracy.

<sup>3</sup> One analogue integration is possible without a loss in accuracy.

<sup>4</sup> Please refer to the sensor input for the allowed input signal.

*Brüel & Kjær Vibro reserves the right to change specifications without notice*

---

**Brüel & Kjær Vibro A/S**  
2850 Nærum – Denmark  
Tel.: +45 7741 2500  
Fax: +45 4580 2937  
E-mail: [info@bkvibro.com](mailto:info@bkvibro.com)

**Brüel & Kjær Vibro GmbH**  
64293 Darmstadt – Germany  
Tel.: +49 (0) 6151 428 1100  
Fax: +49 (0) 6151 428 1200  
E-mail: [info@bkvibro.de](mailto:info@bkvibro.de)